



Harvey Norman[®]

FURNITURE & BEDDING

**TERMS of SALE
& CARE GUIDE**

LOVE
your
FURNITURE
for
YEARS
to come



Table of Contents

- Page 1: Essential checks before ordering
Payment
Cancellations – purchases made in store
Cancellations – purchases made online
Availability
Lead Times
- Page 2: Delivery Access
Storage
Delivery Service
Delivery Time
Warehouse Collection
- Page 3: Returns policy – purchases made in store
Returns Policy – Purchases made Online
- Page 4: Damaged/faulty goods
Quality Control
Mattress Care & Maintenance
- Page 5: Bedroom Furniture Care & Maintenance
- Page 6: Motion Bases
- Page 7: Bunk Beds Care & Maintenance
- Page 8: Assembly of Beds and Furniture
- Page 9: Wood Care & Maintenance
- Page 10: Glass Furniture Care & Maintenance
Marble/Stone Care & Maintenance
Ceramic Table Care
- Page 11: Sofa Care & Maintenance
- Page 15: Sofa Bed Care Tips
S10 Sofaplan
- Page 16: Rugs
Candle Care
- Page 17: Warranty
Report a fault with a product
- Page 19: Sofa Orientation

ESSENTIAL CHECKS BEFORE ORDERING

These terms are in addition to our general sale terms available at www.harveynorman.co.uk. It is the customer's responsibility to ensure that the Furniture and Bedding items that have been ordered will fit into the room for which they are intended, that they will fit through all access points to the room and that there is sufficient access for a large delivery truck to reach the delivery address. *Fees for redelivery may apply..

PAYMENT

A minimum deposit of 20% is payable on placing your order. A greater deposit will be required for all custom made or special orders. Full payment must be received before delivery/collection of goods. Errors in pricing are subject to correction with your approval. If you do not approve Harvey Norman reserves the right to cancel the sale. Please confirm the prices at point of purchase.

CANCELLATIONS – PURCHASES MADE IN STORE

Cancellations or changes to an instore order more than 48 hours after the order is placed may incur a cost of up to 20% of the price of the products as a contribution towards costs incurred by us. Cancellations are not permitted on custom orders where an item has been ordered to your exact specifications or on any non-standard combination orders.

CANCELLATIONS – PURCHASES MADE ONLINE

We must be informed of your decision to cancel and return your order within 14 days from the day after delivery of the item(s). You have a further 14 days from the date you cancelled to return any item(s) to us.

If you wish to cancel your order and return item(s) you have purchased from our website, you can notify us by completing a Cancellation Form: (<https://www.harveynorman.co.uk/online-order-cancellation-form.html>) or by returning the item(s) to your local store.

*See Returns Policy – Purchases made Online (page 3)

AVAILABILITY

Our product ranges are updated regularly so we cannot always guarantee continuity of supply. We therefore recommend that customers purchase all of their requirements at once. We are unable to accept responsibility for any subsequent changes in design style or specification of the chosen product range.

LEAD TIMES

Our products are subject to availability from our suppliers, we can only give general guidance or an approximate lead time when you place your order. Stock due dates are not guaranteed but we will do our utmost to ensure products are delivered by the stated date or within a reasonable period thereafter. We will of course make every effort to keep you informed and to ensure the approximate lead time is accurate.



DELIVERY ACCESS

The delivery crew will not attempt delivery if there are health and safety issues or where damage to your home may result. They will not remove doors or windows. Road access to the delivery address must be suitable and adequate for the delivery vehicle so that unloading can be carried out conveniently without obstruction or damage. All doorways, hallways, elevators, and points of access in your property must be measured by the customer to ensure that they are adequate for the size of the goods being delivered. If the delivery team have difficulty placing an item in the area of your choosing due to limitations such as narrow halls, stairways, corners or ceiling heights, the items will be placed in another area of your home. If you insist that the delivery team manoeuvre an item in a restricted area, you will be responsible for any resulting damages to the furniture and the premises. Prior to delivery please ensure that all access routes, flooring and door frames are protected. Harvey Norman will not accept responsibility for any damage caused where floor covering protection was not used.

STORAGE

Items that are in stock and /or are ready for delivery will be held in storage for a maximum period of 4 weeks. Storage fees will apply after this period. A charge of £25.00 per week is applicable to all items held in storage.

DELIVERY SERVICE

We offer a delivery service on all items. A delivery charge applies to all home deliveries and the service is carried out by a trained one or two-man crew. Any claims relating to personal property or damaged products during delivery should be reported directly to your store of purchase immediately.

DELIVERY TIME

Although we are unable to give a specific time of day for deliveries, we will try to accommodate all customers where possible. The delivery team will contact you to schedule your delivery and the driver will contact you on the day of the delivery to confirm a timeframe. In the event that a scheduled delivery is cancelled by you, or a redelivery must take place, a fee will apply.

WAREHOUSE COLLECTION

All items must be paid in full prior to collection. Customers must have a copy of the original sales invoice and present this at the Warehouse Collection Point as proof of purchase. Please consider the dimensions, size and suitability of the vehicle that is being used to collect goods. If items cannot be loaded safely or without damage into the pickup vehicle, our warehouse teams may politely refuse to do so. For goods collected for pickup, transport will be entirely at the risk of the customer. Please inspect all of your new products at the time of pick-up. If there are any items that do not meet your approval, please inform the warehouse team immediately

RETURNS POLICY – PURCHASES MADE IN STORE

If you have changed your mind or if you're unhappy with your purchase, please let us know. Unless faulty, this must be within **30 days**. Small furniture and bedding items should be returned to us, preferably to the original store of purchase. The unwanted items must be accompanied by the original receipt and returned in an **unopened, as sold, resaleable** condition. By this we mean:

- You have not opened or used the product
- The product is in its original packaging, the labels are in good condition and the product can be resold at full price
- If the product has security seals these must be unbroken and intact
- All original components are included with the product being returned.
- The product contains no personal data and is not registered to a user

For large furniture and bedding products that have been delivered, unless faulty, these items(s) must be returned in an **unopened, as sold, resaleable condition** and a restocking fee will apply. The restocking fee is calculated at 30% of the value of the item and an uplift or collection charge will be applied.

We are unable to refund or exchange imperfect goods where the imperfection was identified to you prior to purchase (for example, where you have knowingly purchased an imperfect display model). Returns, unless faulty are not permitted on custom orders where an item has been ordered to your exact specifications or on any nonstandard combination order. Similarly, any item which has undergone assembly cannot be returned unless a fault has occurred. Refunds will be processed back to the original method of payment that was used for the original purchase and will be issued once the goods have been returned to us.

RETURNS POLICY – PURCHASES MADE ONLINE

We are happy to assist you with the return of items purchased online that are unsuitable once we are notified within **14 days** from the day after delivery of the item(s). Once we are informed of your decision to cancel and return your order, you have a further 14 days from the date you cancelled to return any item(s) to us. While the item(s) are in your possession you must take reasonable and appropriate care of them. They must be in a **resaleable, as sold** condition. By this we mean:

- You have kept all original packaging and labels in good condition and the products can be resold at full price.
- You have not used the product.
- The product contains no personal data and is not registered to a user.

Refunds will be processed back to the same payment method that was used for the original order and will be issued once the goods have been returned to us.

Please be aware that we will refund your delivery cost only if the return is as a result of our error (e.g. faulty product or incorrectly shipped). If you wish to return an order due to a change of mind you will be responsible for all delivery costs when returning goods to a store or a warehouse.

*** Some exclusions to our returns policy apply. Where installation on large domestic appliances and kitchen appliances has already begun. Where items that are not in a resaleable as sold condition. Where packaging and labels have been disposed of. For software products where the tamper proof seal has been broken and on custom orders or bespoke products.*

DAMAGED/FAULTY GOODS

All goods must be inspected on receipt of delivery/collection and any damage i.e. scratches, tears, dents etc. must be reported at the earliest possible opportunity to Harvey Norman. If your item is faulty, we are happy to offer you an exchange or a refund within 30 days of purchase or home delivery. After this time and during the warranty period, we may be able to repair the faulty product or replace it in accordance with the terms of The Consumer Rights Act 2015. Please note we do not offer exchanges, refunds or repairs if your item is faulty due to accidental damage, normal wear and tear, negligence or misuse. Harvey Norman reserves the right to inspect any damage reported before a repair or return is agreed.

QUALITY CONTROL

Please be advised that our warehouse teams will sometimes quality check items by opening the packaging to examine the product before it is dispatched to the delivery company. This is done to ensure that only furniture of the highest quality is delivered to your home.

MATTRESS CARE & MAINTENANCE

Before using the product, open all packaging in a well-ventilated room and leave uncovered for at least 24 hours. Due to materials used during production, there may be an odour from your mattress for a number of weeks.

We would strongly recommend the use of a mattress protector on all mattresses. Occasionally vacuum the surface of your mattress to remove dust and let your mattress air regularly.

Always follow your manufacturer's cleaning and care label instructions. If you spill something on your mattress make sure you extract as much of the spill as possible – mattresses don't dry out easily. You can stand it on its side to minimise the penetration of moisture and allow it to air dry away from direct heat.

Body Signatures

These are the impressions the body makes on the surface or comfort layers of the mattress where the main weight of the body has been lying. Body Signatures are normal and indicate that the mattress is adapting and conforming to the body shape. Generally a depth between 25-35mm is normal within the first 12 months. If the depth of the depression is greater than 40mm, further investigation may be required. These values may vary for plush mattresses due to the thickness of the comfort layers. The more plush the mattress, the more noticeable the Body Signature may be.

Please refer to the manufacturer's instructions in relation to rotation or turning of the mattress. Some mattresses need to be flipped while other mattresses need to be rotated head to toe. Ensure not to bend or roll your mattress. Bending or rolling your mattress will damage the spring unit. Sitting on the edge of your mattress for long periods can also affect its shape. Mattresses should be used on an appropriate supportive base or frame. Avoid placing a board between your mattress and your box spring - it can interfere with the supporting function of the box spring. Check that legs and castors are tightened fully from time to time.

Issues relating to comfort cannot be attributed to a manufacturing fault.

BEDROOM FURNITURE CARE AND MAINTENANCE

To clean, simply dust. Wipe away any stains with a moist cloth, followed immediately with a dry cloth to avoid watermarks. However, should you need to remove any heavier stains, please use a neutral detergent, taking care not to over rub - rinse with clean, lukewarm water. We recommend that you avoid placing the bed near radiators. Similarly, direct sunlight may cause some fading.

Proper centre supports make a world of difference when it comes to your complete bedding setup. Not only do supports add to the comfort of your mattress, they also prevent damage to your bed. Without them, your mattress will almost certainly start to sag. If you are placing your bed on a wooden/tiled floor we recommend the use of a rubber mat under the feet to prevent them from slipping on the ground.

Adjustable centre feet should not touch the ground, there should be a slight gap between the foot and the floor to allow for movement and to avoid it getting bent if the bed moves. Also take care when moving the bed for cleaning that you straighten the centre foot afterwards so that it is offering the correct support. Please refer to the manufacturer's instructions for full details.

Ottoman Storage Base

An Ottoman base comes with a gas assisted lid that allows the lid to open (from the bottom of the base) and close with ease. Once assembled the mattress support will not operate correctly unless a mattress is placed on top of it.

For the safety of yourself and others, please ensure that:

- Only the handle is used when lifting and lowering the frame. Failure to comply with this warning may result in injury and finger entrapment
- The strap is attached and always left outwards as shown in the assembly instructions
- The mattress support is fully raised and locked in the 'up' position before using the ottoman space, otherwise the frame could fall and cause injury or break.
- Children and pets are not left unattended when the frame is in the lifted position as they could become trapped in the ottoman space.

Check the assembly screws and piston arm periodically to ensure that they are secure.

Motion Bases

Please heed the manufacturer's weight restrictions and assembly instructions

Connect the base to a power supply. We recommend using a surge protector. Incorrect power connection may cause electric shock or fire. This product presents a risk of electric shock or injury if used incorrectly.

- Do not attempt to open or disassemble the components in the process of using the product.
- Before commencing maintenance or cleaning of the base, ensure the base is completely flat, then unplug from the power source to avoid electric shock.
- Do not allow the power cord to be placed or rested on or near hot surfaces.
- Keep the base away from flammable substances as this will pose a significant safety risk.
- Keep body parts clear of all moving parts to avoid injury while the product is in use. Keep moving parts clear from obstruction during operation, such as sheets, clothing and wiring.
- Before adjusting, make sure children and pets are clear of moving parts and are not under bed base.
- Use caution with liquids in or around the base. In case of spillage, unplug the base.
- Keep bed in a flat position when not in use.
- Do not allow children or pets to play under the base. Store the remote safely and keep away from children and pets. Children should only use this product under adult supervision.
- Do not leave devices or leads plugged into USB ports when unattended
- Customers with a pace maker should check the suitability of this product prior to purchase





Bunk Beds Care & Maintenance

We recommend bunk beds for children aged 6 and over.

Always heed the manufacturer's weight restrictions and assembly instructions.

Allow only one person on the top bunk. Advise children about the risks and identify safety rules where bunk beds are concerned.

Unless the area under the bed is designed by the manufacturer as a play area or study centre we recommended against playing on or under bunk beds.

Encourage children to use the ladder (or the stairs if this is a stairway bunk bed) when climbing on and climbing down from the top bunk.

The recommended way to climb both up and down is facing the ladder holding on to it securely.

Take care not to place bunk beds near windows, curtains/blinds or within 2 metres of a ceiling fan or light fitting. Ensure the bed has all guard rails installed at all times, even if the bed is pushed up against a wall. Ensure the mattress is the correct size for the bed.

We recommend the use of a step ladder/footstool when making the top bunk. Breakages in side rails resulting from standing on side rail while dressing the top bunk, will not be covered by warranty.

Check regularly to make sure the bed frame is sturdy and free from signs of wear and tear. Tighten all fittings, especially on the ladder regularly.

Check for any gaps that may trap fingers, limbs and heads.

ASSEMBLY OF BEDS AND FURNITURE

When opening the box/packaging please do not use a knife or a blade.

Having unpacked your furniture, check that it is complete and all parts are present. Ensure all fittings have been removed before disposing of packaging. This should not be left within reach of children as it may be dangerous.

For 'self-assembly' furniture, read the assembly instructions before starting. Identify the parts of your furniture and follow the assembly sequence. Avoid use of force when assembling parts; be careful not to over tighten fittings during assembly.

In order to avoid any damage during assembly, use the appropriate tools and work on a surface covered by carpet or other protective layer. For gluing operations (drawers for example), use the glue provided and leave assembled parts to one side for one hour to allow the glue to dry in a well ventilated area.

Please note, the feet for certain products may be found in the zip pocket underneath the suite.

Assembly and installation must be done in accordance with our instructions. Failure to follow assembly instructions may result in poor performance of your product and void your warranty. This warranty does not cover any damaged or defective parts that result from incorrect installation and assembly, abuse, negligence or improper use. If instructions are not followed, we decline any liability in the event of damage caused to people or property as a result of incorrect installation. Where assembly instructions specify safety measures (markings for example), they must be complied with, if not, we will under no circumstances be considered liable for any harm that may occur. Where maximum loads are stated, please do not exceed these as this may lead to sub-standard performance, possible damage to the product and even collapse.

Installing your furniture

Once assembled, position the furniture, ensuring it is level so that doors and drawers open and close properly; fixing it will facilitate adjustment (hinges or runners). Check the final stability of the furniture.

When positioning the furniture please do not drag, items should be lifted by the bottom base. After assembling a table, with the aid of another person, carefully lift the table and turn it over into the upright position. Take care not to put pressure on legs when turning as this may damage the base or joints.

Felt pads or gliders should be used under all Bedding and Furniture products.

If you need to move your furniture, you must empty it; this will make handling easier and avoid risks of breakage or injury. This does not apply to furniture fitted with casters; emptying the furniture in this case is at your discretion.

Note If stated in the assembly instructions, furniture must be fixed to the wall using furniture safety straps and fixing provided.



WOOD CARE & MAINTENANCE

Whether you have an all-wood piece of furniture or a furnishing made of a mix of wood, man-made wood (engineered materials) and wood veneer, you want to protect it from damage, maintain its perfect finish and keep it looking beautiful for years to come. Here are some tips to help you do that.

Care: Solid woods may expand and shrink with changes in temperature and humidity. Take care not to place your furniture next to radiators or anywhere that could be subject to excessive changes in temperature or moisture. Avoid placing furniture directly under windows.

We recommend that all kitchenware and beverages should be placed on coasters, mats and hot pads. Clean up spills immediately as liquid left sitting for a long period may cause staining or soak into the product and cause damage. If this happens typically white stains appear and bubbles may appear in the top coat. Please note that furniture may only be covered with an oilcloth for a maximum of 12 hours at a time in order for the wood to breathe.

Shelves or drawer boxes should not be overloaded beyond capacity. For drawers that sit directly on the ground, bear in mind that carpet pile will restrict the free movement of drawers. Always use the handles provided to open and close drawers/doors. It is recommended that all self-assembled products should be periodically checked to ensure that all the fittings are secure. Do not over tighten the fittings.

Cleaning: To clean, use a duster or lint free cloth regularly. Never use all-purpose chemical/cleaning sprays on your wood furniture. You should not use soap and water on a regular basis as it can stain and damage the wood. Use soap and water sparingly to get rid of hard stains. Dry and buff immediately with a dry cloth to avoid staining. In the event of more stubborn marks, a solution of mild detergent should be used on the cloth. Silicone based polishes should not be used on the wood as they will build up and leave a sticky residue on the surface.

Heat: Never place hot items such as dishes directly onto a table or surface without using a heat resistant mat or trivet as direct heat will draw out the moisture in the wood. This could leave a ring mark ingrained into the wood. Very hot items such as a saucepan or baking dish should never be placed on a table top, even with a hot pad. Avoid placement of heated electrical equipment, cigarettes, candles etc. on furniture tops and surfaces. Use protective mats and ashtrays.

Colour Variations: Colour differences in woods are to be expected and knots, shading and grain differences are a natural characteristic and can sometimes be non-uniform in appearance. This is a feature and not a fault of these products. The colour of wood will naturally mellow with age. However, prolonged exposure to direct sunlight may accelerate this process.

GLASS FURNITURE CARE & MAINTENANCE

Tempered glass surfaces offer a high level of safety; as a matter of fact, in case of breakage, the glass will crumble into small fragments. Try to prevent accidental breakages of tempered glass: do not place hot or cold objects on the surface, and avoid impact with hard or sharp objects. As with wood, use of coasters will protect the surface of your furniture. Take care to avoid sliding rough objects across glass as this can cause permanent scratches to the surface.

Clean your glass surfaces regularly using mild soap or non-abrasive glass cleaner. Gently remove excessive dirt and debris first to avoid scratching glass. Then using a non-abrasive glass cleaner or mild soap and water, wipe surface. Dry immediately with a dry lint free cloth.

MARBLE/STONE CARE & MAINTENANCE

Marble is a beautiful surface for tabletops, natural variations and veins in the stone are highlighted by polishing. However, because it is porous marble can easily be stained and scratched. To prevent ring marks, place coasters or trivets under glasses and dishes. Use mats or runners beneath hard objects that might scratch the surface and always blot spills up immediately and clean with a damp cloth.

Highly acidic substances such as orange juice, coffee, vinegar, wine, tomato products, mustard and many soft drinks may 'etch' the surface. This is a chemical reaction that may leave a dull mark. General cleaners not specifically designed for stone are not recommended as they may etch or discolour the surface or scratch the stone.

Regular cleaning should be as gentle as possible. Dust the surface once or twice a week with a soft cloth. Wash the marble periodically with a cloth dampened with warm water and, if necessary, a small amount of dishwashing liquid. Remove the soap with another damp cloth. Remember to always wipe the surface of the table dry as regular exposure to moisture can damage the condition of any natural stone.

CERAMIC TABLE CARE

Less is best when it comes to cleaning ceramic table tops, which means more time enjoying meals with family and friends and less time worrying about the clean-up later. Just wipe the surface with a damp cloth or sponge and a mild detergent, like the soap you would normally use in the kitchen.

Although dirt cannot penetrate into the ceramic material, it is necessary to remove it from the surface in order to prevent the build-up of surface grease and contaminants. Day to day maintenance of ceramic table tops can be performed by simply wiping down using a clean, microfibre cloth and warm, diluted, neutral detergent to remove surface spillages. Spillages of wine, coffee, ketchup, oils and acidic substances such as vinegar should be wiped clean immediately.



SOFA CARE & MAINTENANCE

In order to ensure that your sofa gets to you in the best possible condition, we package it well to protect it on its journey to your home. During the journey, crush marks may appear on your sofa but please do not be alarmed, these will naturally work their way out over a few weeks. Fillings may also have flattened and need to be plumped up in the same manner you would regularly 'dress' your sofa.

When removing the protective wrapping, do not use sharp tools that may damage your sofa covering.

The seat cushions on your sofa may appear to be firmer than those you sat on in the showroom, but please be aware that your seat foam will soften with use. Softening of padding and cushions causes light creasing, wrinkling of fabric and slight stretching of the leather which is considered to be normal wear. It helps, especially when you first get your sofa, to remember to rotate your seating pattern. This ensures even wear and helps your cushions last longer.

If the sofas are to be used on floorboards, we recommend the use of floor protectors.

The frame of your sofa is made up of many different components including wooden frames, springs and metal mechanisms. Wood responds to heat, humidity, and other changes of climate by expanding and contracting. Equally, a new recliner mechanism with all of its moving parts will take some time to settle. With this in mind your new sofa might make some noise as the different parts of your furniture react and adjust to its new environment. With time this will settle and the noise will disappear.



As dust and dirt will cause your sofa to wear faster, we recommend vacuuming regularly with an upholstery attachment. Keep furniture out of direct sunlight and at least two feet from heat sources. This will minimize fading of colour and in the case of leather furniture avoid fading and cracking. Dark colours and natural fibres are most susceptible to fading.

Note that sun screen and lotions, certain medications and chlorine are harmful to any upholstery and can cause discolouration. Blue jeans can also transfer blue dye to many coverings.

If there is a need to move furniture, always remember to lift rather than pull. Dragging can put pressure on joints, zips and stretch/damage upholstery. Avoid sitting on the arms, or edge of furniture as this may cause distortion or damage. Pushing feet against or placing them on the arms may cause damage to the arm or frame.

Issues relating to comfort cannot be attributed to a manufacturing fault.

How to model and shape your new sofa

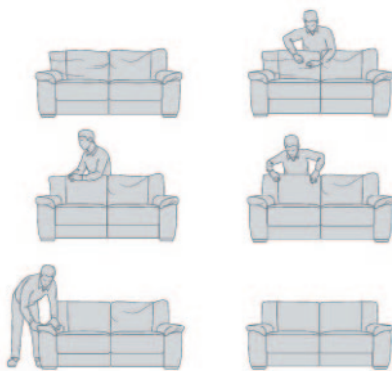

Fillings

It may not be uppermost in your mind, but the filling in your chosen sofa does make a difference. Just as they offer different levels of support, sofas and chairs will require different levels of maintenance depending on the filling. Follow our tips to help you to look after your sofa and enjoy it for many years to come.

Foam upholstery will feel firm and supportive; the firmer the foam the firmer the sit. It lends a more tailored appearance and will recover well. Over time, the foam will compact and lose volume a little, though this process is much slower with high resilience foam.

Fibre wrap. Soft polyester fibre is wrapped around a foam core. It provides a good level of support with a soft top layer. It has a more relaxed, casual look and a softer sit – ideal if you like to curl up on the sofa. Turn and plump cushions weekly to maintain comfort and wear. To do this effectively, hit cushions on all sides and drop them onto a clean floor to get some air back into them.

Foam & feather. The core consists of a higher density foam, wrapped top and bottom with duck or goose feathers. These types of cushions provide the best characteristics of feather and foam, the softness, support and comfort of feather mix combined with the stability and resilience of foam. As with your pillow, plump daily to maintain appearance and ensure even distribution of filling.

Pocket Sprung. If you are after a firmer feel, our individually pocketed coils will offer you all the support you need, the pocket springs are in the core of the interior and surrounded by foam. Multi spring requires minimum maintenance and gives a neat appearance.

Leather Care Tips

Leather is a natural product can vary in look and appearance, it will stretch and crease with age. Leather furniture rarely retains its new look, cushions will soften and relax their shape with regular use, making them even more comfortable. This adds to the character of leather over the years. It has natural markings, from variation of shade and tone, healed scars and scratches, to skin 'stretch marks' and insect bites. By no means should they be considered a defect; nor will they affect the durability of your piece. Such 'imperfections' are your assurance that you have true leather hide. Leather is highly resilient and over time develops a patina that increasingly enhances its appeal. Also keep in mind, grain patterns and colouring of leather will vary from hide to hide and also within the same hide, making leather all the more interesting and unique.

Avoid placing sharp objects on leather goods. Leather is very durable; however, it is not accident or damage proof. Refrain from leaving newspapers or magazines on leather furniture. The ink from these items may be transferred onto the leather. Avoid placing hot items such as cups, laptops or hot water bottles on leather as this may mark the leather, causing it to darken.

Only use recommended leather cleaners and test in an obscure area first. Avoid abrasives, harsh chemicals, saddle soap, leather cleaners that contain any oils, soaps or detergents, or common household cleaners on leather furniture. Aniline leathers require particular care, as they lack a protective coating. Use products specifically designed for these types of finish and follow instructions carefully. Improper cleaning may void your leather furniture warranty. For large or persistent stains, contact a professional upholstery cleaning company.

Leather characteristics:

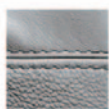

Differences in the grain



Stretch mark
(fat marks)



Scars

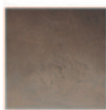

Scratches



Difference in tone

Fabric Care Tips

In order to maintain the appearance and condition of your fabric, it is useful to develop a regular maintenance routine. We recommend against removing cushion covers for separate cleaning, even though they may have zippers. Treat spills and stains as soon as possible. Gently scrape any soil or mop liquid from the surface of the fabric without scrubbing. Apply proprietary cleaning agents strictly according to instructions to remove the residue of the spill. Do not saturate the fabric with water or other cleaning liquids. (If you have Guardsman Protection Plan, contact them immediately). An annual professional cleaning will keep your upholstered furniture looking its best.

Pilling is a normal occurrence caused by wear and tear, and does not affect the durability or functionality of the fabric. It is important to note that pilling is not a fabric defect or fault, and is not covered under warranty. This is completely normal and will reduce once the excess fibres are gone. Fibre pills can be removed by a battery operated pilling tool available from most haberdashery stores. Velvet and chenille fabrics have a raised surface texture which is prone to flattening and shading. The surface of any fabric will wear, however this should not be taken as an indication that material is worn out.

Recliner Care Tips

When your sofa arrives, you may need to cut the cable ties from underneath to release the mechanism. Sofas with working mechanisms will require enough clearance room both in front of and behind to extend fully. As the recliner contains moving parts, slight noises will be audible when the recliner is operating. When sitting on a recliner you must be aware that leaning or sitting sideways across the recliner arms can put pressure on the central anchor points and cause buckling of the frame or mechanism. Do not sit on the footrest when raised. There will be a gap in the seats to allow for the free movement of the mechanism. This is normal and will reduce the risk of wear on the fabric in these areas.

Manual Recliner

To activate a manual recliner pull the release cable and to close, use two legs pushed in the centre of the recliner to a fully upright position.

Electric Recliner

Plug in the lead from the transformer unit into an appropriate domestic mains electric supply, ensuring the cable is not routed where it can become trapped by the mechanism. To open the footrest, press and hold the open button. By continuing to press the open button the back will move to the recline position. To return the back to the upright position and close the footrest, simply press and hold the close button.

Do not place the chair/sofa, cables or transformer

- Underneath or close to any other object of furniture
- In an area which is exposed to long periods of sunlight
- In or near an area which is, or may become, wet or damp
- Near open fires, heaters, gas or electrical appliances.

Never dismantle the motor or transformer.

Do not attempt to exit the chair/sofa whilst in the reclined position, wait until the chair/sofa is fully closed.

Do not leave devices or leads plugged into USB ports when unattended.

Sofa bed Care Tips

As with a new mattress, before first use, open all packaging in a well-ventilated room and leave uncovered for at least 24 hours. Sofa beds are designed and intended for occasional use only, as continuous use may lead to premature wear to the mattress and frame.

Remove bed sheets and blankets before closing the bed frame. Although sofa bed action is manufactured to stringent specifications, please do not sit on the edge of the bed once opened as this may cause the frame to bend. Always refer to the manufacturer's instructions for cleaning the sofa and the mechanism.

Top tips for sofa care:

- When moving your sofa, do not lift it by the cushions sewn to the frame or move your sofa by dragging it around. The best way is to lift it from the base.



- To avoid your sofa fading, do not expose it to direct sunlight.



- When removing the protective wrapping, do not use sharp tools that may damage your sofa covering.



- Your sofa should be placed at least 50cm away from any heat source.



- During the first 3 months, foam padding will become softer. Light creases may form on the cover following this. This is to be considered as normal wear.

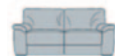

- To keep your sofa looking its best, you should plump and shape it weekly to ensure padding and upholstery return to their initial appearance.



- As tempting as it may be, armrests and backrests are not designed as seating.



- For even wear you should alternate your choice of seat.



S10 Sofaplan

Every sofa we sell comes with our industry leading S10 Sofaplan. It means peace of mind. The S10 Sofaplan structural warranty is exclusive to Harvey Norman and covers every structural component of your new sofa, including framework, joints and suspension (webbing or springs). This means that, should any structural component of your furniture fail during the first ten years, it will be repaired completely free of charge. Unless otherwise stated, all furniture and bedding products purchased at Harvey Norman are covered for a period of one year.



RUGS

Regular maintenance and taking care of your rugs is important to extending the life of them. Here are some quick tips to help you.

One of the first things that you should do is vacuum your rug regularly. Vacuuming is an important step as it aids in removing loose dirt from the rug, and makes the cleaning process easier in the long run. We recommend using the nozzle attachment of a Hoover rather than abrasive, rotary brushes that can damage the fibers.

If you spill liquid on the rug we recommend that you blot the stain with a clean white cloth or paper towel. Apply lots of pressure to absorb as much liquid as possible. Once you have done this you should clean with a mild, clear detergent and lukewarm water taking care not to saturate the area. Blot the dampened area to remove excess moisture trying not to rub. If a stain cannot be removed, seek specialist advice. For any other stains such as food or mud, scrape any excess off first and then follow the same steps as above.



CANDLE CARE

Please follow these guidelines to ensure that you get the best from your candles while staying safe

Read and follow the manufacturers use and safety instructions carefully. Unless otherwise indicated only burn for 3 hours at a time.

Always place your candle on a flat, heat resistant surface. Keep out of reach of children and pets and never burn a candle on or near anything that can catch fire.

Burn your candle in a well-ventilated room, away from drafts, to keep the flame as steady as possible. Long wicks can cause a high flame and potential flaring so trim the wick to 6mm each time before burning. If the flame becomes too high, extinguish and let cool, then trim the wick.

Never leave burning candles unattended and avoid burning the candle to the end. Discontinue using when 1cm of wax remains.

If you like to group candles, always make sure they are at least 8cm apart when burning, otherwise they can create their own draft and cause the flames to flare up.

WARRANTY

All furniture and bedding products purchased at Harvey Norman are covered by warranty. (Additional structural cover for your sofa is covered by our S10 sofa plan – details on page 15). Extended warranty may be purchased on certain products for further peace of mind. Visible surface damage (scratches, nicks, tears, etc.) are not covered under warranty unless reported within the first 30 days of delivery. Warranty does not cover normal wear and tear.

All products are intended for domestic use, and we give no guarantees or undertakings in respect of the use of our products for commercial purposes. Our guarantees are limited to goods sold and retained in the UK and used solely in private residences and not in commercial or rental properties. The warranty is void if Harvey Norman determines that any damage to the furniture was caused by abuse, negligence, accident or if used for purposes other than which it was intended. Visible surface damage (scratches, nicks, tears, etc.) are not covered under this warranty unless reported within the first 3 days of delivery. Warranty does not cover normal wear and tear.

REPORT A FAULT WITH A PRODUCT

If you wish to return a Furniture or Bedding product or want to talk to us about a damaged item, please contact your store of purchase or visit our Contact Us Page on our website www.harveynorman.co.uk/customer-services/contact-us.html. If your item was damaged or faulty when you received it within the first 30 days, we will offer an exchange, replacement or refund once we have verified the fault. In some cases, we may be able to offer you a discount to keep the item if the damage is cosmetic and you are happy to keep it with a partial refund. After the first 30 days of purchase or from the date of delivery, if the product is still within the warranty period, we will arrange a repair using our specialist service agents or an exchange or replacement of your item. For small furniture and bedding products, please return the product to one of our stores. To find your nearest store, please use our store locator on our website www.harveynorman.co.uk/store-finder.html

The contents of this brochure exist in addition to and do not affect your statutory rights.

**Thank You For Shopping at
Harvey Norman!**

Notes

A series of horizontal dotted lines for writing notes.

Sofa Orientation

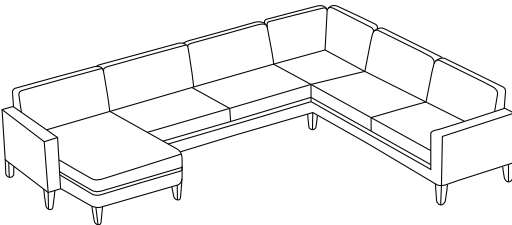
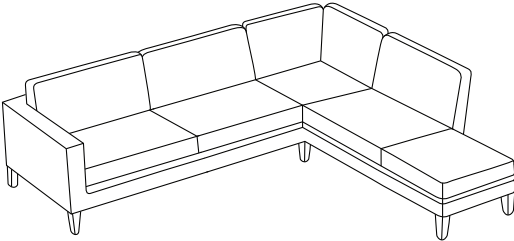
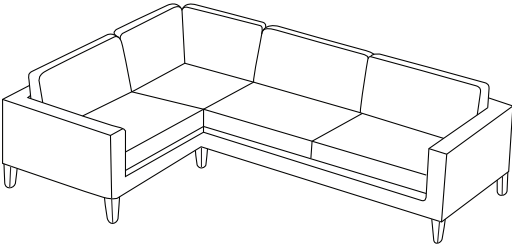
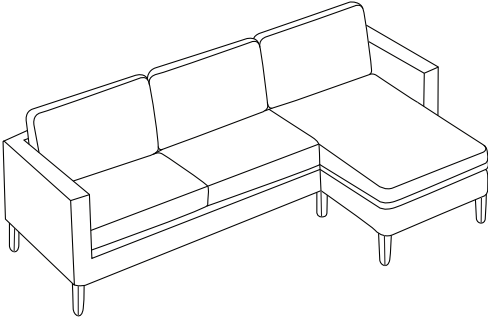

Invoice Number : _____

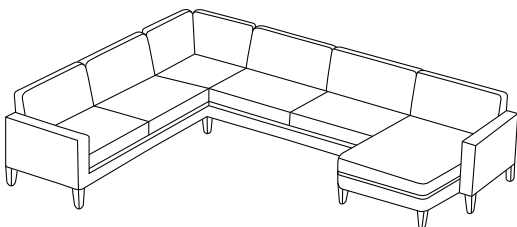
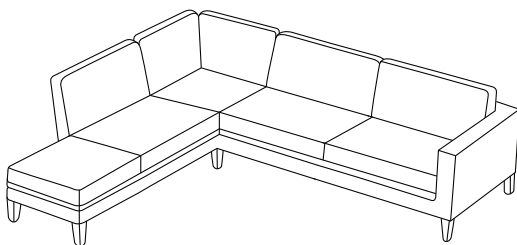
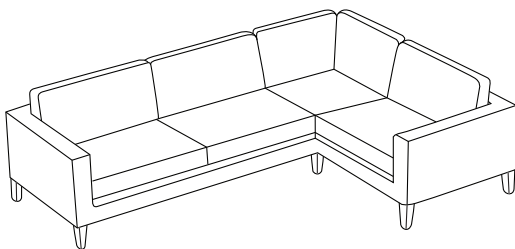
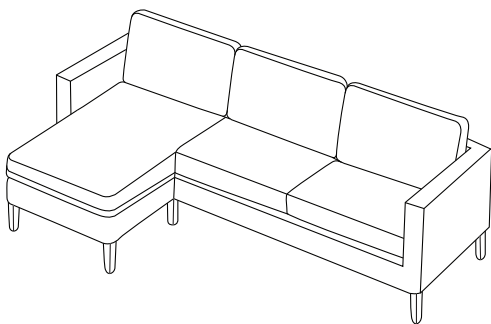



Harvey Norman[®]

www.harveynorman.co.uk